



# Stackable Single Bunks

Manufactured by Bob Barker Company, Inc.

Revised 09/01/03

Bob Barker Company, Inc. reserves the right to make engineering changes or other modifications at our discretion without notice.

**If double-decked units are desired, order bunks in multiples of two.  
Each bunk is furnished with stacking hardware.**

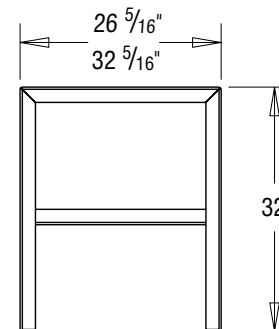
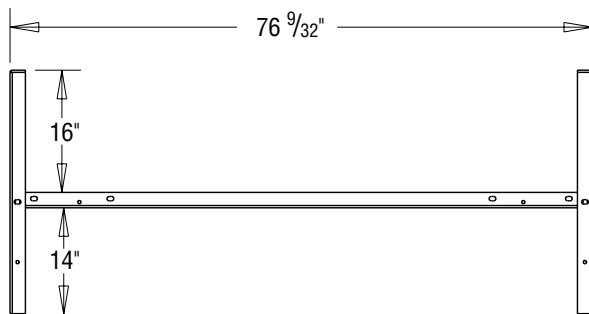
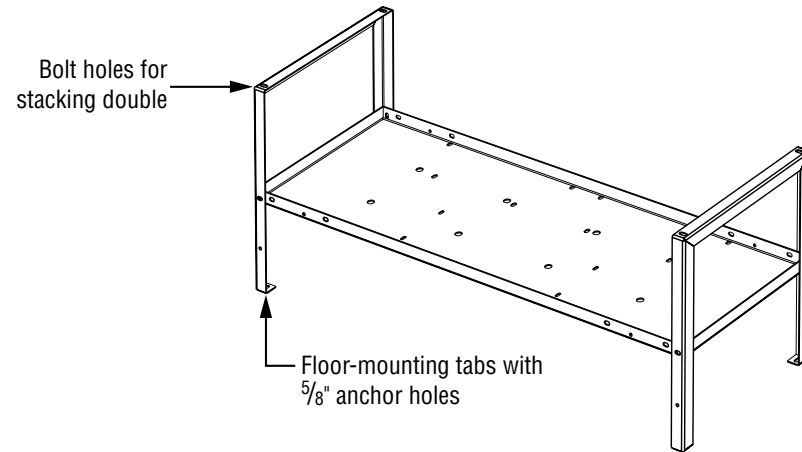
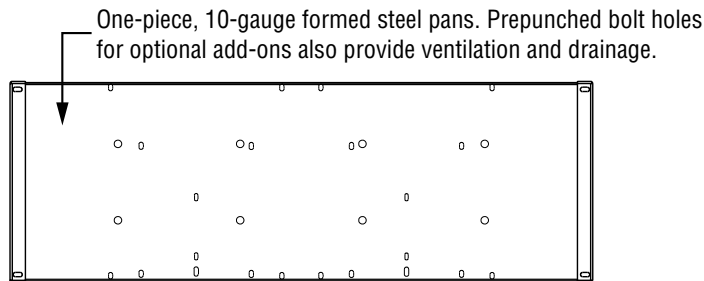

**Stackable bunks should be securely anchored to the floor.  
Each bunk requires 4 anchors for floor attachment.**

### Standard Options

Ladders, Lockable Under-Bunk Storage Drawers and Open Under-Bunk Storage Shelves. Security Bolt and Expansion Wedge Anchor Kits.

### Fabrication Options

Custom designs, materials, sizes, colors and finishes.



Item #	Legs	Actual Sleeping Surface	Weight
STACK27B	Bolt-On	27" W x 76" L	118 LBS.
STACK32B	Bolt-On	32" W x 76" L	134 LBS.
STACK27W	Welded	27" W x 76" L	109 LBS.
STACK32W	Welded	32" W x 76" L	126 LBS.