



Stackable Single Bunks

Manufactured by Bob Barker Company, Inc.

Revised 09/01/03

The BarkerBuilt® Advantage

Practical design, heavy-duty construction and premium powder coat finishing. BarkerBuilt's triple-feature profile provides exactly what you're looking for - a full line of quality metal furnishings that will give years of high-performance, low maintenance service in abuse-prone correctional and detention settings.

Materials

All materials are new and free from imperfections that may adversely affect appearance or durability. All sheet steel is cold-rolled, pickled and oiled furniture grade.

Construction

One-piece, 10-gauge formed steel pans. Prepunched bolt holes for optional add-ons also provide ventilation and drainage. 10-gauge formed steel legs are 2" x 2". Each leg has one floor-mounting tab with one 5/8" anchor hole at the bottom and bolt hole at the top for stacking double. Legs are either factory-welded to the frame or shipped detached for easy bolt-on field assembly. Bolts, lock-washers, nuts and leg braces are provided with bolt-on leg models. Legs can be field-welded if desired.

Welding

Exposed welds are ground smooth in non-critical areas. Unexposed welds do not require finish grinding, but have good uniform appearance. All welds are thoroughly fused and sound.

Finish

Gray full finish powder coat, for excellent resistance to corrosion, heat, impact, abrasion and fading. Automatic three stage cleaning and pretreatment with in-line oven drying and electrostatic application of powder provides a fully finished 3 MIL. (avg.) coating weight of 60-70 gloss or textured surfaces. No need for additional painting after installation.

Standard Options

Ladders, Lockable Under-Bunk Storage Drawers and Open Under-Bunk Storage Shelves. Security Bolt and Expansion Wedge Anchor Kits.

Fabrication Options

Custom designs, materials, sizes, colors and finishes.

Warranty

Bob Barker Company, Inc. warrants our detention furnishings to be free of any defects in materials or workmanship for one (1) year from the date of project completion. Our liability is strictly limited to the repair or replacement of units that in our opinion are found defective. This warranty is in lieu of all other warranties, expressed or implied.

Double-Decker Stackable Single Bunks shown with optional Ladder and Under-Bunk Storage Shelves.

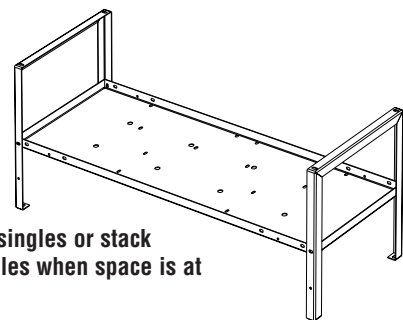
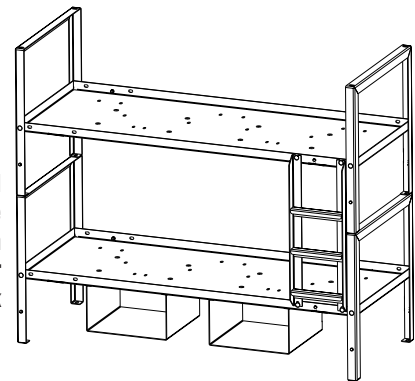

Use them as singles or stack them as doubles when space is at a premium.



Bob Barker Company, Inc.

1-800-334-9880 ph. • 1-800-322-7537 fax

www.barkerbuilt.com